

D13-MH

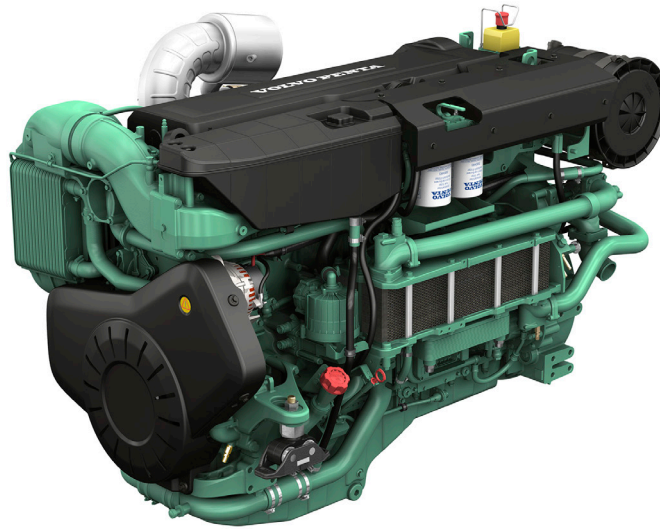

Technical Data

Engine designation	D13 MH				
No. of cylinders and configuration	in-line 6				
Method of operation	4-stroke, direct-injected, turbocharged diesel engine with charge air cooler				
Bore/stroke, mm (in.)	131/158 (5.16/6.22)				
Displacement, l (in ³)	12.78 (779.7)				
Compression ratio	18.5				
Dry weight bobtail (KC), kg (lb)	1480 (3263)				
Dry weight bobtail (HE), kg (lb)	1520 (3351)				
	Rating 1	Rating 1	Rating 1	Rating 2	Rating 2
	1800 rpm	1800 rpm	1800 rpm	1900 rpm	1900 rpm
Crankshaft power, kW (hp)	294 (400)	331 (450)	368 (500)	404 (550)	441 (600)
Max. torque, Nm (lbf.ft) @ 1400 rpm	1756 (1295)	1975 (1457)	2164 (1596)	2363 (1743)	2399 (1769)
Specific fuel consumption,					
g/kWh (lb/hph) @ 1400 rpm	202 (0.33)	200 (0.32)	200 (0.32)	197 (0.32)	197 (0.32)
g/kWh (lb/hph) @ 1800 rpm	208 (0.34)	211 (0.34)	212 (0.34)	211 (0.34)	207 (0.34)
Emission compliance	EU IWW,	EU IWW,	EU IWW,	EU IWW,	EU IWW,
	IMO NO _x ,	IMO NO _x ,	IMO NO _x ,	IMO NO _x ,	IMO NO _x ,
	CCNR Stage 2,	CCNR Stage 2,	CCNR Stage 2,	CCNR Stage 2,	CCNR Stage 2,
	US EPA Tier 3	US EPA Tier 3	US EPA Tier 3	US EPA Tier 3	US EPA Tier 3
Recommended fuel to conform to	ASTM-D975 1-D & 2-D, EN 590 or JIS KK 2204				
Flywheel housing/SAE size	14"/SAE1				
Technical data according to ISO 3046 Fuel Stop Power and ISO 8665. Fuel with a lower calorific value of 42700 kJ/kg and density of 840 g/liter at 15 °C (60 °F). Merchant fuel may differ from this specification which will influence engine power output and fuel consumption. Ratings R1 & R2, see explanation in Volvo Penta's Product Guide.					

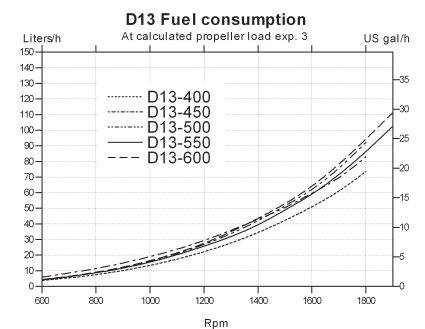
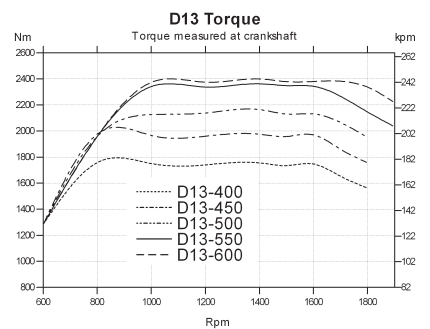
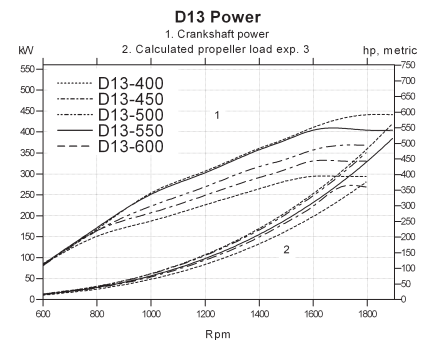

VOLVO PENTA

D13-MH

Technical description:

Engine and block

- Cylinder block and cylinder head made of cast-iron
- One-piece cast-iron cylinder head
- Ladder frame fitted to engine block
- Replaceable wet cylinder liners and valve seats/guides
- Drop forged crankshaft with induction hardened bearing surfaces and fillets with seven main bearings
- Four valve per cylinder layout with overhead camshaft
- Each cylinder features cross-flow inlet and exhaust ducts
- Gallery oil-cooled cast aluminum alloy pistons with three piston rings
- Rear-end transmission

Engine mounting

- Flexible engine mounting (option)

Lubrication system

- Integrated oil cooler in cylinder block
- Twin full flow oil filters and by-pass filters of spin-on type

Fuel system

- Electronic Unit Injectors, one per cylinder, vertically positioned at the center in between the four valves
- 5-hole high pressure injector nozzles
- Gear-driven fuel pump, driven by timing gear
- Electronically controlled central processing system (EMS – Engine Management System)
- Electronically controlled injection timing
- Twin spin-on fine fuel filters with change over valve

Air inlet and exhaust system

- Air filter with replaceable inserts
- Mid-positioned twin entry turbocharger and charge air cooler

Cooling system

- Freshwater-cooled charge air cooler
- Seawater-cooled plate heat exchanger
- Coolant system prepared for hot water outlet
- Easily accessible seawater impeller pump in rear end

Electrical system

- 24V/110A alternator

Instruments/controls (option)

- Complete instrumentation including key switch and interlocked alarm
- EVC monitoring panels for single or twin installations
- Electronic remote control for throttle and shift
- Plug-in connections
- SDU shutdown unit for classified installations
- MCC – Marine Control System

Dimensions D13 MH

Not for installation

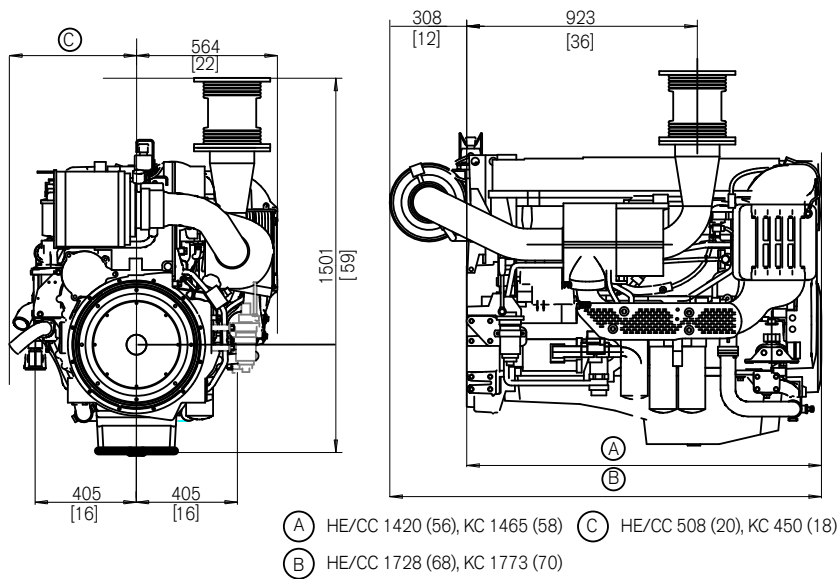

More information

Contact your local Volvo Penta dealer for more information regarding Volvo Penta engines and optional equipment/accessories or visit www.volvopenta.com



IOS



Android

Download the Volvo Penta dealer locator App for your iPhone or Android

VOLVO PENTA

AB Volvo Penta

SE-405 08 Göteborg, Sweden
www.volvopenta.com

Not all models, standard equipment and accessories are available in all countries. All specifications are subject to change without notice. The engine illustrated may not be entirely identical to production standard engines.